

SHANTUI

SG14

Motor Grader



Engine Model: Cummins 6BTAA5.9-C150
Gross Power: 112kW @ 2200rpm
Operating Weight: 11,600kg

We Level Subgrade Fast and Flat
easy operation and maintenance

SG14 SPECIFICATIONS

ENGINE

Model	Cummins 6BTA5.9-C150
Number of cylinders	6
Type	4-cycle, direct injection, water-cooled
Bore x stroke	102*120mm
Displacement	5.9L
Rated power	112kW @ 2200rpm
Max. traction	65kN
Max. torque	670N.m @ 1400rpm
Rated fuel consumption	223g/kW.h
Emission	China-II

POWER TRAIN

Transmission	Fixed-axis type, electro-hydraulic control
Torque converter	Single-stage, single-phase, three basic elements
Rear axle	Modular, planetary reduction, "no-Spin" anti-skid differential
Tandem drive	Roller chain, Oscillating angle: $\pm 15^\circ$
Tire	13-24PR12
Front axle	Oscillating angle: $\pm 15^\circ$ Tilting angle: $\pm 17^\circ$

STEERING

Front wheel steering angle	$\pm 45^\circ$
Articulation angle	$\pm 25^\circ$
Min. turning radius	6600mm

BRAKES

Service brake	Drum type, foot operated, single circuit, hydraulically actuated on four tandem wheels
Parking brake	Drum type, manually actuated

MOLDBOARD

Type	Hydraulic power, replaceable cutting edges, hardened cutting edges and end bits
Rotation	360°
Moldboard width	3660mm
Moldboard height	615mm
Moldboard thickness	20mm
Moldboard tip angle	30~68°
Max. cutting depth	500mm
Max. lifting height	440mm
Max. shoulder reach (left/right)	1700/2000mm
Max. tilting angle (left/right)	$\pm 90^\circ$

SPEED

Forward, 1-6	5.4\18.3\13.2\20.6\29.6\44km/h
Reverse, 1-3	5.4\13.2\29.6km/h

HYDRAULICS

Tandem pump	Gear pump, 28ml/r
Relief pressure for working equipment	16MPa

CAPACITIES

Fuel tank	220L
Hydraulic oil tank	85L
Engine crank case	15L
Engine coolant	26L

ELECTRICAL SYSTEM

Battery	2x12V, 105Ah
Alternator	28V, 45A
Starter motor	24V, 6kW

OPERATING WEIGHT

Standard	11600kg
With rear ripper	12851kg

RIPPER (OPTIONAL)

Ripping depth	255mm
Shank supports	5\9
Shank support spacing	400/200mm
Working width	1865mm

MIDDLE SCARIFIER (OPTIONAL)

Scarifying depth	240mm
Shank holders	11
Working width	1230mm

DIMENSIONS

A Overall length: Standard	8040mm
A Overall length: With rear ripper	9310mm
B Front axle to tandem center	5800mm
C Length: Between tandem axles	1540mm
D Height: Cab	3170mm
E Tread	2130mm
F Width: Outside tires	2380mm
G Moldboard width	3660mm
H Minimum ground clearance	430mm

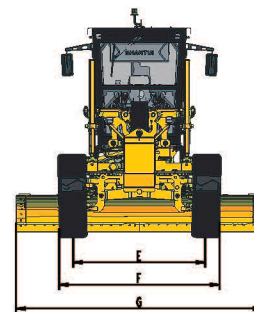
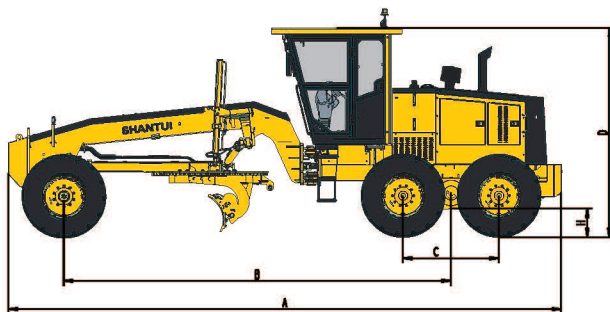

* THE SPECIFICATIONS ARE SUBJECT TO CHANGE WITHOUT NOTICE. THE PICTURES MAY INCLUDE OPTIONS. THE ACTUAL COLOR & APPEARANCE OF THE PRODUCT MAY DIFFER FROM WHAT IS SHOWN.



Shantui Social

SHANTUI CONSTRUCTION MACHINERY CO., LTD.
 ADD: No. 58, G327 Highway, Jining City, Shandong, CHINA
 TEL: +86-537-2909369
 FAX: +86-537-2311219
 EMAIL: trade@shantui.com
 WEB: www.shantui.com

SHANTUI
 LET'S MAKE CONSTRUCTION EASIER