

Model	Capacity @ 600 mm LC	Fuel Type	Engine
2070H	7,000 kg	Diesel	Chaochai CY6102BG / 5.785 L
2070H	7,000 kg	Diesel	ISUZU A-6BG1QC-02 / 6.494 L

2070H

Diesel
Pneumatic Tire Forklifts



TOUGH WORLD. TOUGH EQUIPMENT.

2070H Diesel • Pneumatic Tire Forklifts



General	1	Model			2070H	2070H
	2	Power Type			Diesel	Diesel
	3	Base Capacity	@ rated load center	kg	7,000	7,000
	4	Load Center		mm	600	600
Weights	5	Service Weight	unloaded	kg	9,300	9,300
	6	Axle Load	loaded / unloaded, front	kg	14,460 / 3,800	14,460 / 3,800
	7		loaded / unloaded, rear	kg	1,840 / 5,500	1,840 / 5,500
Tires	8	Tire Type			Pneumatic	Pneumatic
	9	Wheels	front / rear		4 / 2	4 / 2
	10	Wheelbase		mm	2,250	2,250
	11	Tire Size	front		8.25-15-14PR	8.25-15-14PR
	12		rear		8.25-15-14PR	8.25-15-14PR
	13	Tread Width	front / rear		1,474 / 1,730	1,474 / 1,730
Mast	14	Max. Fork Height	with std 2-stage mast	mm	3,000	3,000
	15	Freelift	with std 2-stage mast	mm	210	210
	16	Height, Upright Lowered	with std 2-stage mast	mm	2,534	2,534
	17	Height, Upright Extended	with std 2-stage mast	mm	4,377	4,377
	18	Mast Tilt, Fwd / Bwd	with std 2-stage mast	deg	6° / 12°	6° / 12°
	19	Carriage	width	mm	1,840	1,840
	20	Fork Spread	minimum / maximum	mm	300 / 1,836	300 / 1,836
	21	Fork Dimensions	T x W x L	mm	65×150×1,520	65×150×1,520
Chassis	22	Length to Fork Face	with std 2-stage mast	mm	3,584	3,584
	23	Overall Width		mm	2,040	2,040
	24	Overhead Guard Height		mm	2,520	2,520
	25	Turning Radius	minimum outside	mm	3,550	3,550
	26	Fork Overhang	with std 2-stage mast	mm	592	592
	27	Right Angle Stack	add load length and clearance	mm	5,542	5,542
	28	Ground Clearance	minimum loaded	mm	203	203
	29		center of wheelbase	mm	250	250
Performance	30	Travel Speed	loaded / unloaded	km/h	28 / 32	23 / 25
	31	Lift Speed	loaded / unloaded	m/s	0.48 / 0.6	0.4 / 0.52
	32	Lower Speed	loaded / unloaded	m/s	0.55 / 0.4	0.55 / 0.4
	33	Max. Drawbar Pull	loaded	kg	5,500	5,500
	34	Max. Gradeability	loaded / unloaded	%	30 / 20	30 / 20
Systems	35	Brakes	service		Foot / Air over Hyd	Foot / Hyd
	36		parking		Hand / Mech	Hand / Mech
	37		manufacturer		ChaoChai	ISUZU
	38	Engine	model		CY6102BG	A-6BG1QC-02
	39		emission compliance		China Tier II	Euro Tier I
	40		cylinders		6	6
	41		displacement	liter	5.785	6.494
	42		rated power	kW/rpm	81 / 2,500	82.4 / 2,000
	43		max. torque	N · m/rpm	353 / 1,650	4,16.8 / 1,500

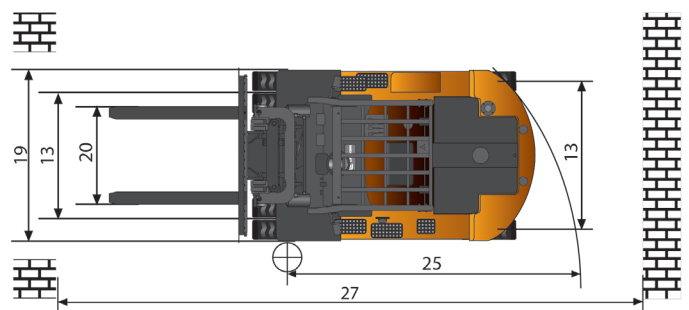
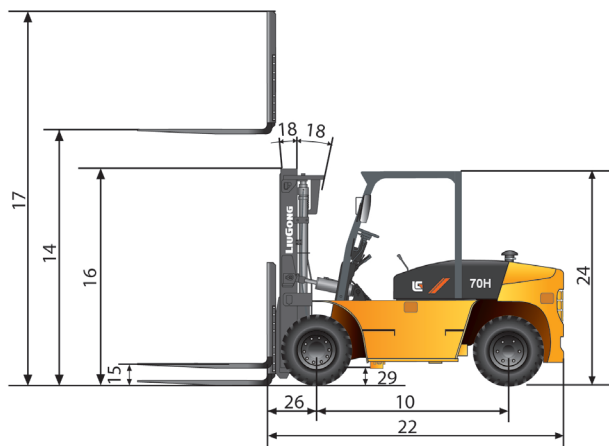

Guangxi Liugong Machinery Co., Ltd.

No. 1 Liutai Road, Liuzhou, Guangxi 545007, PR China
 T: +86 772 3886124 E: overseas@liugong.com
 www.liugong.com

02/2014 Designed by Liugong